

High Fronted Gutters



High Fronted Gutters

High fronted gutters hide the lower edge of tiles or roof cladding which creates an aesthetically pleasing appearance. It is important that sufficient overflow measures are included in the design of the guttering system and that high fronted gutters are installed in such a way that if they overflow, it will not result in water flowing back into the roof or building.

The design of gutter and downpipe system installations also need to comply with specific rainfall intensities for the area of installation and adequate overflow provisions need to be provided to prevent water from entering the dwelling during heavy rainfall periods.

Codes

The design and installation of guttering and downpipe systems needs to comply with the Building Code of Australia and Australian Standards AS/NZS 3500.3 Plumbing and Drainage, Stormwater Drainage and AS/NZS 3500.5 National Plumbing and Drainage, Domestic Installations. It is also important that relevant State regulations are satisfied. For example, New South Wales legislation requires all gutter and downpipe installations be undertaken by a suitably licensed installer who holds a current certificate issued by the NSW Office of Fair Trading.

Natural Effects

There are two natural effects in Stratco guttering that offer some protection against water flowing from eaves gutters inside a building, when attached to Stratco steel fascia.

- The first is that when installed on our steel fascia, the “high front” of the gutter can still be lower than the top face of the fascia. Water will always flow to the lowest point, and even if a complete blockage exists, should still overflow outside the eaves line (Figure 1 and 3).

- Secondly, if a complete blockage occurs the additional weight of the water will cause the gutter to temporarily deform. The back of the gutter is restrained at 1.2 metre intervals by fixing clips but between these points the gutter moves outwards from the fascia creating a gap that allows the additional water to escape (Figure 4).

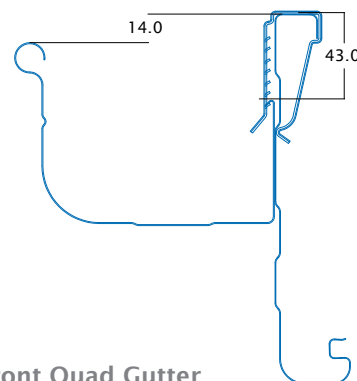

High Front Quad Gutter

Responsibilities of the Designer

Notwithstanding the natural effects mentioned above it is still the responsibility of the designer of the rainwater goods system (who may be the architect, builder, hydraulic engineer, home owner, roofing or guttering contractor) to design a rainwater system which allows adequate drainage to occur. Water should not be able to flow back into the building.

- For eaves gutters they must determine the rainfall intensity values (ARI) shown in AS3500 part 3.2 "Stormwater drainage – Acceptable solutions".
- For a specific rainfall intensity they should determine the cross sectional area of gutter best suited to their situation, when the roof catchment area is taken into account. A table showing the effective cross sectional area of Stratco gutters is shown in (Table 2) and a further table (Table 3) allows you to determine which Stratco gutter suits your needs. While you can choose whether slotted or non slotted gutter best suits your needs, Stratco recommend the slotted option where possible.
- Where the designer is aware of specific local factors that may impact negatively on the standard design then this must be taken into account in the design. For example if the rainwater goods system is required to be used in a leafy area, then adequate leaf guards may need to be specified. Smaller mesh leaf guards may be required for fine needle like leaves, and these may need to be removable to prevent fungal build-up. All leaf guards need to be removed regularly and the gutter cleaned. In snow or hail prone areas, then gutter either may not be suitable, or may need to be situated well below the level of the fascia with snow breaks installed.
- Increasing the size and frequency of downpipes will assist in the drainage of the roof. The downpipes used in the drainage table (Table 3) must be at least the size used in the cross section area table (Table 2)
- For additional information refer to the Stratco website which shows a roof drainage calculator.
- Where there is any doubt as to the adequacy of the design, or where the designer wishes to introduce a further level of safety, there are a number of additional protective measures

that can be included in the design (Figure 5). They include:

- Using modified stop ends: At the end of gutters normal height stop ends can be replaced by lower stop ends which reduce the depth of water able to collect in the gutter controlling overflow to these points.
- Using an internal outlet: An outlet may be able to be placed in the centre of the gutter which has a top lower than the back of the gutter which releases water prior to the gutter overflowing.
- Using a cut down front: The front of the gutter can be notched to a lower level allowing water to escape past the bead prior to any overflow from the gutters rear.
- Using a front spigot: A small tube or outlet can be attached to the front of the gutter that will allow water to overflow from the gutter front.
- Using a rear exit gap: There are a number of clips and devices on the market which will create a gap between the back of the gutter and the front of the fascia. Whilst this is a satisfactory method, consideration needs to be given to issues such as spider control, and the possible ingress of embers in a fire prone situation.
- Using slots: Stratco, and most gutter manufacturers offer their gutter in a slotted format, which will assist in removing surplus water in a more controlled manner.
- Using other proprietary solutions: There are other proprietary products available which contain various measures to prevent gutters blocking (leafguards of many types) or downpipes blocking (outlets which contain holes and slots) and these may be selected by either the builder or consumer.
- Using rainheads or sumps: Rainheads which have greater inlet areas than ordinary outlets can be placed at strategic points along the length of the gutter into which excess water can discharge, providing greater resilience to sudden downpours and these may be fitted with overflows as well.

These measures can either be used singly, or in combination with each other and will reduce the capacity of the gutter to move the required volume of water. Figure 2 shows several of these used together.

Gutter Overflow Remedies

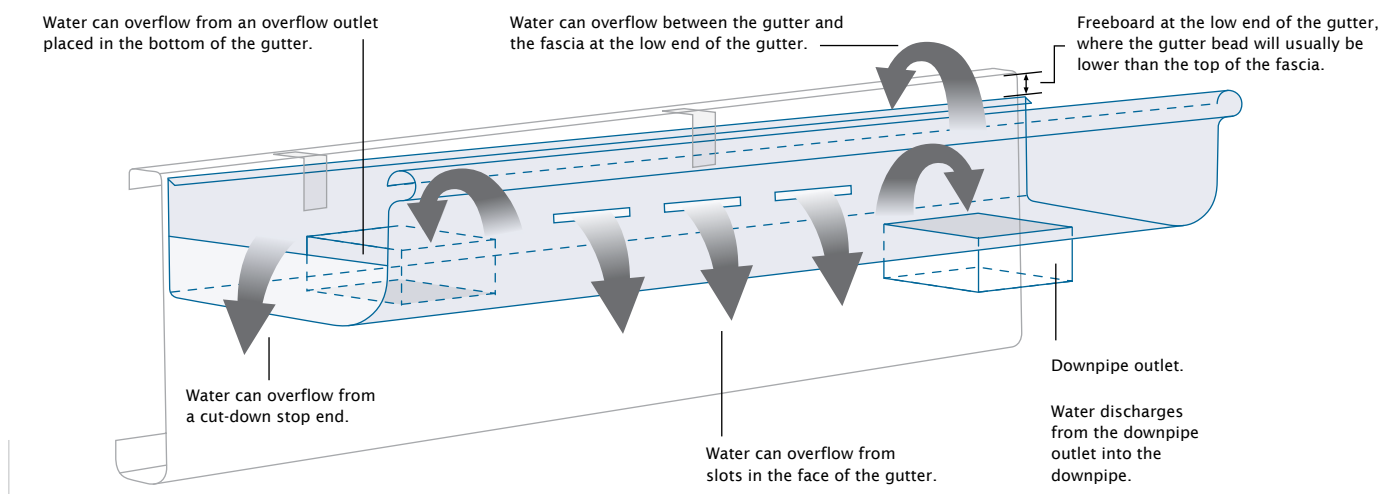

Figure 2

Natural Effects

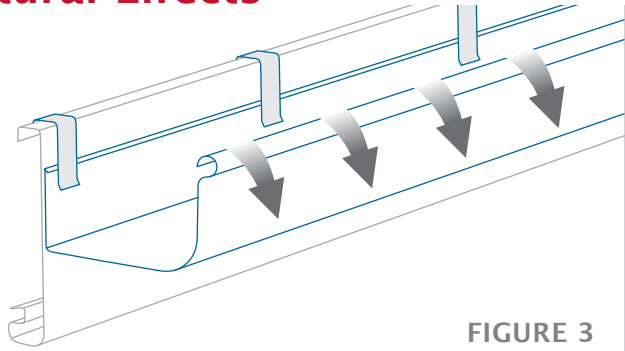

FIGURE 3

Front is Lower Than The Top of The Fascia

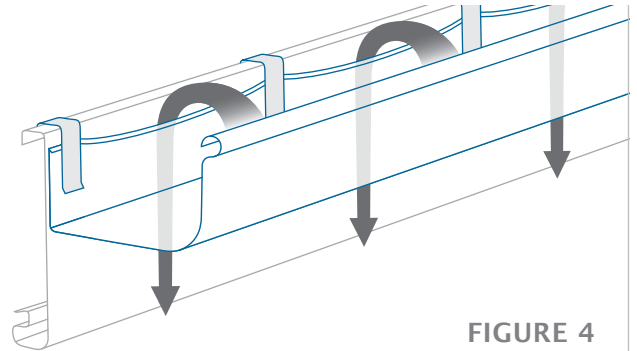
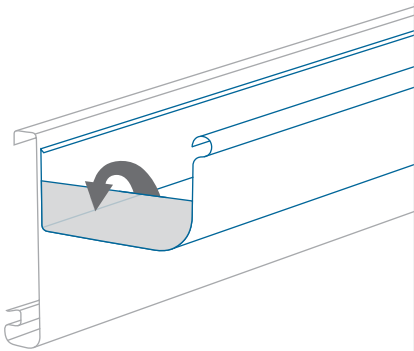

FIGURE 4

Stretch in The Back Face of The Gutter

Additional Measures

FIGURE 5



Modified Stop End

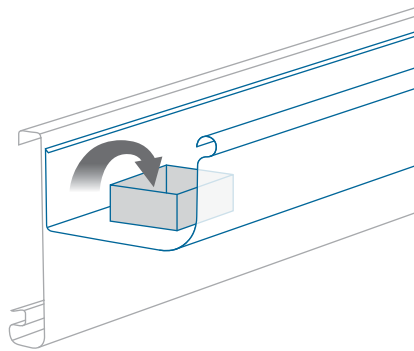

Internal Outlet

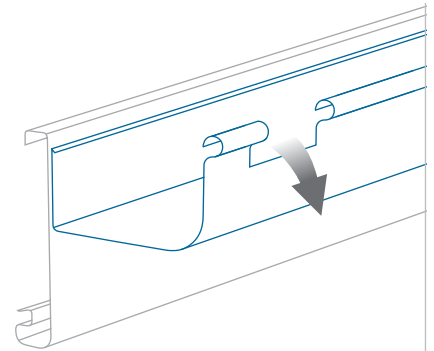

Front Cut-Down

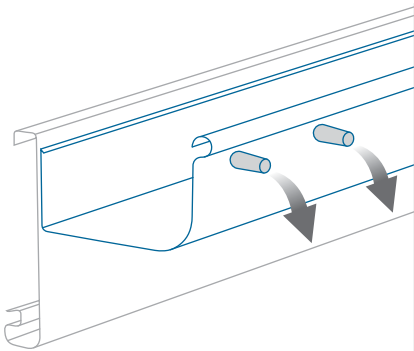

Front Spiggot

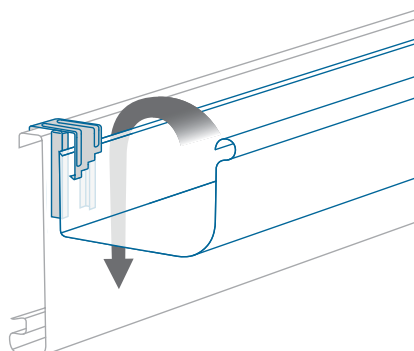

Rear Exit Gap

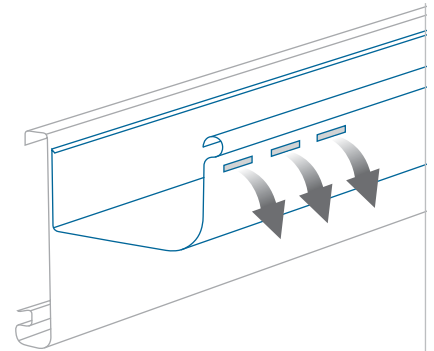

Front Slots

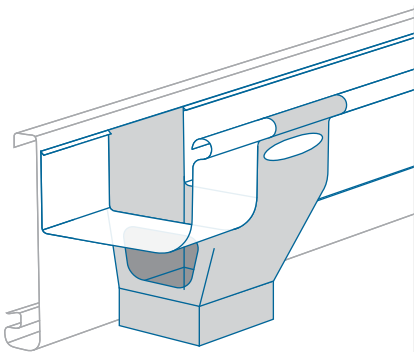

Propriety Solution

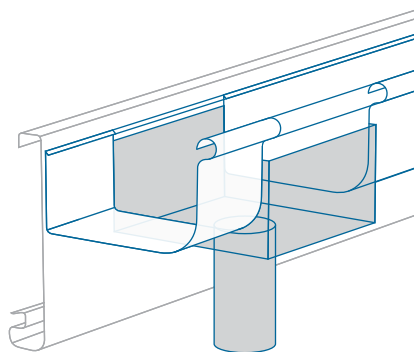

Sump

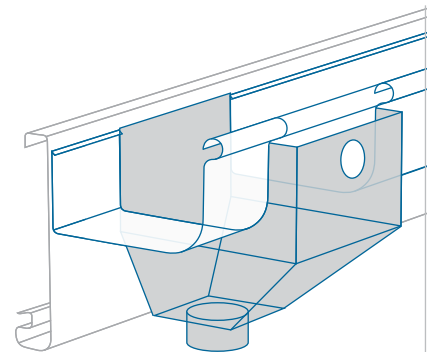

Rainhead



Table 1 | Design Rainfall Intensities (mm/h)

Average Recurrence: Once in 20 Years (Minimum for eaves gutters).

ACT		Taree	190	Hamilton	120	WA	
Canberra	137	Tweed Heads	245	Healsville	129	Abydos	199
NSW		Wollongong	233	Horsham	120	Albany	142
Albury	135	Wyong	186	Korumburra	116	Broome	252
Armidale	154	TAS		Lakes Entrance	124	Bunbury	148
Batemans Bay	211	Bridgewater	101	Melbourne	127	Carnarvon	142
Bathurst	143	Burnie	118	Mildura	125	Collie	145
Bowral	170	Deloraine	108	Morewell	129	Dampier	231
Broken Hill	130	Dover	97	Orbost	130	Derby	254
Casino	198	Flinders Island	128	Stawell	127	Geraldton	132
Coffs Harbour	232	Hobart	99	Wonthaggi	114	Halls Creek	181
Cooma	129	Kingston	98	QLD		Hammersley	180
Coonabarabran	178	Launceston	101	Biloela	220	Hillside	192
Cowra	144	Mt Wellington	122	Brisbane	251	Kalgoorlie	116
Dorrigo	214	New Norfolk	100	Bundaberg	241	Katanning	125
Dubbo	159	Queenstown	118	Cairns	282	Kununurra	256
Forbes	151	Scottsdale	119	Cape York	301	Marble Bar	205
Glen Innes	159	Sorell	101	Charleville	170	Meekatharra	111
Gosford	189	St Helens	131	Charters Towers	218	Mundaring	139
Goulburn	145	St Marys	205	Cloncurry	172	Newman	143
Inverell	179	SA		Emerald	220	Perth	146
Kempsey	220	Adelaide	123	Goondiwindi	182	Port Headland	233
Kiama	224	Arkaroola	134	Gympie	228	Roy Hill	160
Kiandra	143	Ceduna	125	Hughenden	199	Tom Price	164
Lismore	219	Mt Barker	120	Innisfall	254	Wittenoom	182
Lithgow	141	Mt Gambier	108	Kingaroy	208		
Maitland	169	Murray Bridge	117	Longreach	189		
Merimbula	207	Nurioopta	111	Mackay	273		
Mittagong	172	Port Augusta	124	Mareeba	219		
Mullumbimby	250	Port Pirie	125	Mt Isa	169		
Murwillumbah	244	Yorke town	118	Mt Morgan	225		
Muswellbrook	141	NT		Noosa	253		
Newcastle	181	Alice Springs	139	Proserpine	272		
Nowra	219	Darwin	285	Rockhampton	248		
Orange	152	Katherine	230	Roma	192		
Penrith	166	VIC		Southport	246		
Port Macquarie	223	Bacchus Marsh	126	Toowoomba	189		
Robertson	228	Ballarat	127	Townsville	260		
Singleton	148	Benalla	133	Warwick	178		
Sydney	214	Geelong	118	Weipa	293		

Note:

- Data obtained from the Standards Australia Installation code for metal roofing and wall cladding SAA HB39-1997.
- Data for other locations may be obtained from Australian Rainfall and Runoff (1987) published by the Institution of Engineers, Australia or may be obtained from local drainage authorities. Data for any locality in Australia is available (to a resolution of 1/40th of a degree of latitude or longitude) from the Bureau of Meteorology.
- Data shown for large cities are the maxima within the greater city areas. Data for specific locations within these areas may be obtained by reference to the above publication or from the Bureau of Meteorology.
- More stringent requirements should be considered for buildings where the avoidance of gutter overflow is of paramount importance.
- All gutters and outlets, particularly box gutters served by internal sumps, need to be regularly inspected and maintained to avoid blockages.

Table 2 | Cross Section Area (mm²)

Gutter Profile	Effective Cross Sectional Area Capacity (mm ²)	Total Cross Sectional Area (mm ²)	Minimum Downpipe Size	
			Round (dia mm)	Rectangular/ Square (mm)
Quad				
115mm Quad	5,621	6,760	90	100 x 50
115mm Quad – Slotted	5,057	6,192	90	100 x 50
115mm Quad – Low Front	4,307	5,429	75	75 x 50
125mm Quad – NSW	6,488	7,833	90	100 x 50
125mm Quad – SA/NT	6,697	7,958	100	75 x 75
125mm Quad – Slotted	5,592	6,842	90	100 x 50
150mm Quad	8,685	10,088	125	100 x 75
175mm Quad	12,213	13,767	125	100 x 100
OG				
125mm OG	4,432	5,609	75	75 x 50
125mm OG – Slotted	3,374	4,432	65	75 x 50
150mm OG – Slotted	5,763	7,055	90	100 x 50
Half Round & Smoothline				
150mm Smoothline	8,748	10,124	125	100 x 75
150mm Smoothline – Slotted	6,961	8,332	100	100 x 75
150mm Half Round	7,703	9,176	100	100 x 75
150mm Half Round – Slotted	7,126	8,597	100	100 x 75
Square				
VC	5,712	6,893	90	100 x 50
VC – Slotted	4,412	5,594	75	75 x 50
LO-Square – Slotted	4,447	5,624	75	75 x 50
VFC	6,775	7,957	100	100 x 75
VFC – Slotted	5,475	6,657	90	100 x 50
VF – SA	7,839	8,970	100	100 x 75
VF – WA	7,333	8,444	100	100 x 75
VF – Slotted	5,475	6,657	90	100 x 50
HI-Square – Slotted	5,974	7,155	90	100 x 50
C-Square – Slotted	5,974	7,155	90	100 x 50
VT – Slotted	6,338	7,583	90	100 x 50
VFM – Slotted	6,711	7,888	100	100 x 75
Miscellaneous				
Edge Gutter	14,856	16,833	-	-
Edge Gutter WA	9,151	10,936	-	-
HK	5,394	6,590	75	100 x 50
HK – Slotted	3,717	4,816	75	75 x 50
S	5,315	6,358	75	100 x 50
S – Slotted	4,609	5,622	75	75 x 50
Clickform – Slotted	5,102	6,303	90	100 x 50
450mm Girth OG Big One – Slotted	9,881	11,551	125	100 x 100
600mm Girth OG Big One – Slotted	26,345	28,615	125	100 x 100
Quarter Round	6,292	7,577	90	100 x 50
Quarter Round – Slotted	5,054	6,309	90	100 x 50



Table 3 | Eaves Gutter Sizes For Various Rainfall Intensities And Roof Catchment Areas Per Downpipe (Based on minimum size downpipe)

Rainfall Intensity (mm/hr)	Roof Catchment Area								
	10m ²	20m ²	30m ²	40m ²	50m ²	75m ²	100m ²	150m ²	200m ²
	Cross sectional area of gutter (mm ²) required to drain above roof catchment area into one downpipe.								
90	1620	2440	3060	4090	4890	6790	8500	12380	15240
100	1780	2670	3560	4445	5330	7390	9280	13030	16640
110	1860	2830	3810	4780	5720	7960	9950	14000	18500
120	1930	3000	4080	5150	6170	8540	10220	15060	19250
130	2000	3160	4360	5500	6570	9060	11390	16110	20610
140	2070	3340	4640	5830	6940	9610	12110	17180	22030
150	2170	3540	4900	6230	7390	10170	12790	18080	23120
160	2240	3730	5170	6530	7810	10750	13500	19000	24000
180	2470	4110	5700	7170	8500	11810	14800	20390	25560
200	2610	4440	6210	7780	9310	12880	16110	22360	28000
225	2900	4920	6780	8530	10240	14110	17720	24720	31000
250	3060	5340	7400	9310	11060	15310	19250	27200	34200
275	3270	5760	7970	10040	12000	16560	20610	28930	36130
300	3500	6190	8530	10750	12890	17730	22170	30770	38200
350	4000	7030	9640	12140	14530	20000	25280	34610	42380

Responsibilities of the Installer

It is the responsibility of the installer to ensure that the project is installed as required by the rainwater goods designer. They also need to ensure that the directions provided in the Codes mentioned above are followed. Adequate fall towards the downpipes must be given to gutters (a minimum of 1 in 500 for eaves gutters and 1 in 200 for internal gutters). The installer must ensure that the correct number of downpipes of sufficient size are installed, that they are clear of debris and able to discharge correctly.

Responsibilities of the Owner

It is the responsibility of the owner to ensure that their gutters and downpipes are adequately maintained and kept completely free of leaf debris, branches and twigs, and both organic and inorganic materials. There is no one solution that can be relied upon to do this, and the best solution may involve a number of strategies. Should the design provided prove inadequate due to local conditions, many of the additional protective measures described above can be retro fitted and may prove beneficial.

Overflow Measures

Examples of continuous and non-continuous overflow measures that may be used in conjunction with each other to meet the relevant requirements are provided in the Building Code of Australia and examples are shown in Figure 6. Continuous overflow measures allow for overflow along the complete length of the gutter, while non-continuous overflow measures are located at specific points along the length of the gutter. Care needs to be taken to ensure the system complies with the Building Code of Australia and the current Australian Standards.

Gutters may become blocked anywhere along their length which means non-continuous overflow measures may not be sufficient to prevent water flowing back into a building.



CONTACT

1300 165 165

Continuous overflow measures

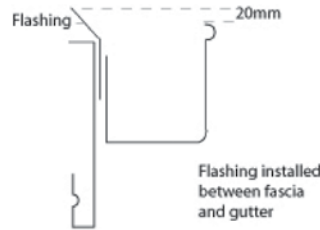
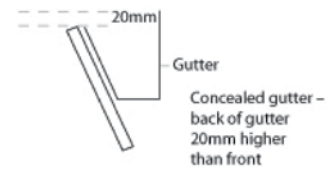
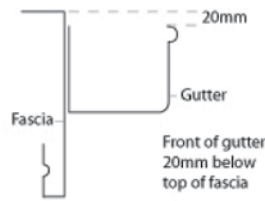

Non-continuous overflow measures

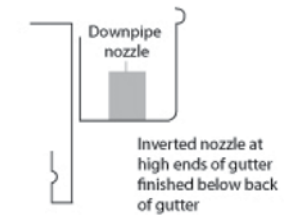
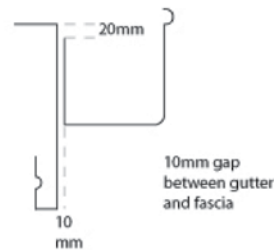
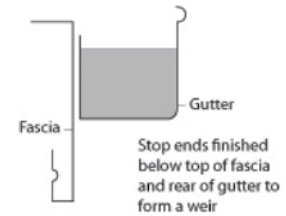

Figure 6

Additional Information

Up to date information about Stratco products, spans, installation requirements and technical advice can be found on our website at: www.stratco.com.au. It is advisable to obtain current information prior to ordering any materials.

Further details about complying with legislation can be found in the Stratco 'Selection, Use and Maintenance' brochure.

The NSW Office of Fair Trading website also provides information on complying with legislation: http://www.fairtrading.nsw.gov.au/Tenants_and_home_owners/Home_building_and_renovating/The_building_process/Residential_gutters.html. If additional information is required contact the Stratco office in your state.

Maintenance

Regular maintenance is essential to maintain the good looks of all Stratco steel products and to ensure you receive the maximum life-span possible in your area. Gutters must be regularly cleaned to prevent the build up of leaf debris, fungus or any other material that could prevent the free drainage of water from the roof. Washing with clean water must be frequent enough to prevent the accumulation of dust, salts, and pollutants or any other material that will reduce the life of the product. Stratco steel products that are regularly washed by rain require no additional maintenance. No Stratco steel structure or materials are recommended for use over, or in close proximity, to swimming pools or spas. No material that retains water (such as dirt or paving sand) should be placed against the columns. Care must be taken when determining the location of Stratco steel products so that they are not placed in close contact with sources of pollution or environmental factors that could affect the life of the steel. Refer to the 'Selection, Use and Maintenance' brochure for more information.